

# INV60Y \_ REV 1.1



DESIGN  
NATALINO MALASORTI

INV60Y/INNOVO  
AISI 316L STAINLESS STEEL

Gruppo miscelatore termostatico  
a parete per vasca/doccia  
con Acqua Stop System,  
deviatore 2/3 vie e doccetta

Wall mounted thermostatic mixer  
set for bath/shower with Acqua  
Stop System, 2/3 way diverter  
and hand shower



PRODOTTI CORRELATI / RELATED PRODUCTS

FRE74 - FRE202 - MIL91



Possibilità di installazione a 180°  
Installation possibility at 180°



Prodotto che necessita di parte incasso  
Product that needs built-in part



Staffa ausiliaria per cartongesso / fibrogesso  
Auxiliary bracket for plasterboard / fiber-board structures



Chiave per pulizia dell'impianto  
Key for cleaning out the water system

MANUTENZIONE / MAINTENANCE

NON UTILIZZARE DO NOT USE		acido clorico e muriatico chloric and muriatic acid
		acido fluoridrico hydrofluoric acid
		ipoclorito di sodio chlorine bleach
UTILIZZARE TO USE		detergente a pH neutro neutral pH detergent

Questi disegni sono proprietà di CEADDESIGN SRL s.u. pertanto non potranno essere utilizzati e/o comunicati a terzi, anche in forma parziale, senza preventiva autorizzazione. CEADDESIGN SRL s.u. si riserva il diritto di apportare modifiche ai disegni al fine di migliorare il prodotto.

CEADDESIGN SRL s.u. has the property rights on these drawings, therefore they cannot be used and/or transferred to third party, even in partial form, without any prior authorization. Furthermore CEADDESIGN SRL s.u. reserves the right to apply any change to these drawings in order to upgrade the product.

# CEA

ceadesign.it

H (mm)

+ UCS25  
750  
(2' - 5 17/32")

250  
(9 27/32")

100 mm  
(3 15/16")

0

L (mm)

INV60Y \_ REV11



#### AVVERTENZE DI INSTALLAZIONE

**L'altezza ottimale di installazione del prodotto è di 250 mm (9 27/32") sopra il bordo vasca.**

La rappresentazione ha valore puramente indicativo.

#### INSTALLATION WARNINGS

**The optimal installation height of the product is 250 mm (9 27/32") above the bath tub rim.**

The representation is purely indicative.

#### INSTALLATIONS WARNUNG

**Die optimale Einbauhöhe des Produkts beträgt 250 mm (9 27/32") über dem Wannenrand.**

Die Zeichnung ist rein indikativ.

#### ADVERTENCIAS DE INSTALACIÓN

**La altura de instalación ideal del producto es de 250 mm (9 27/32") sobre del borde de la bañera.**

La representación es indicativa.

#### AVERTISSEMENTS D'INSTALLATION

**La hauteur optimale d'installation du produit est de 250 mm (9 27/32") au-dessus du bord de la baignoire.**

La représentation est purement indicative.

CEA

ceadesign.it

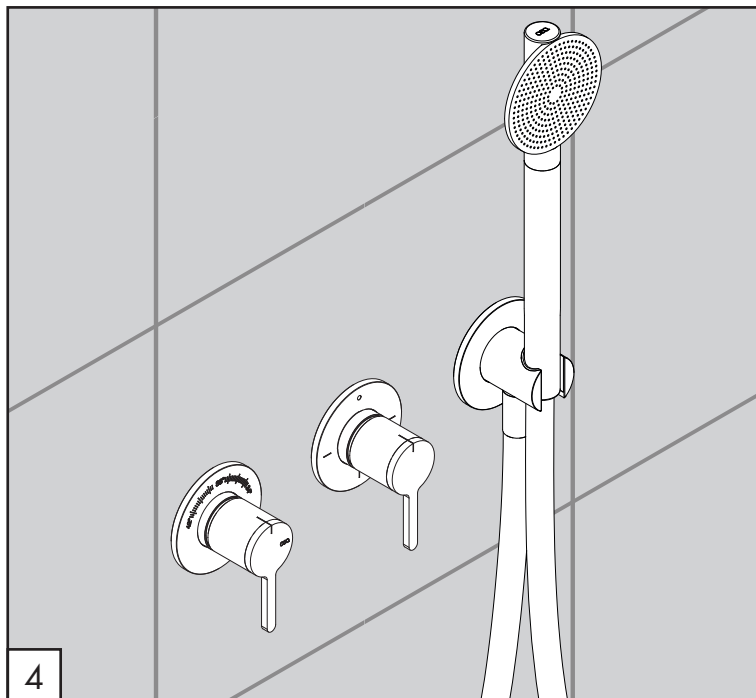
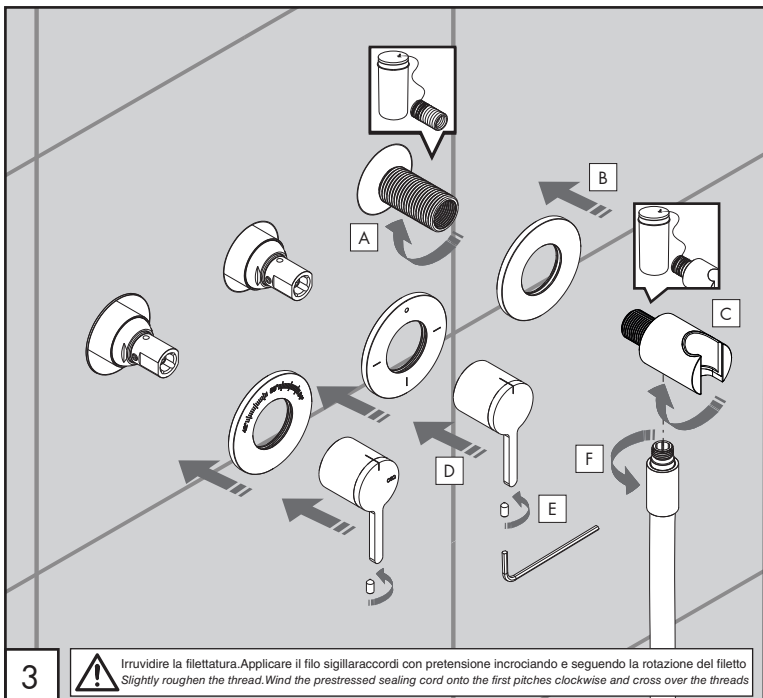
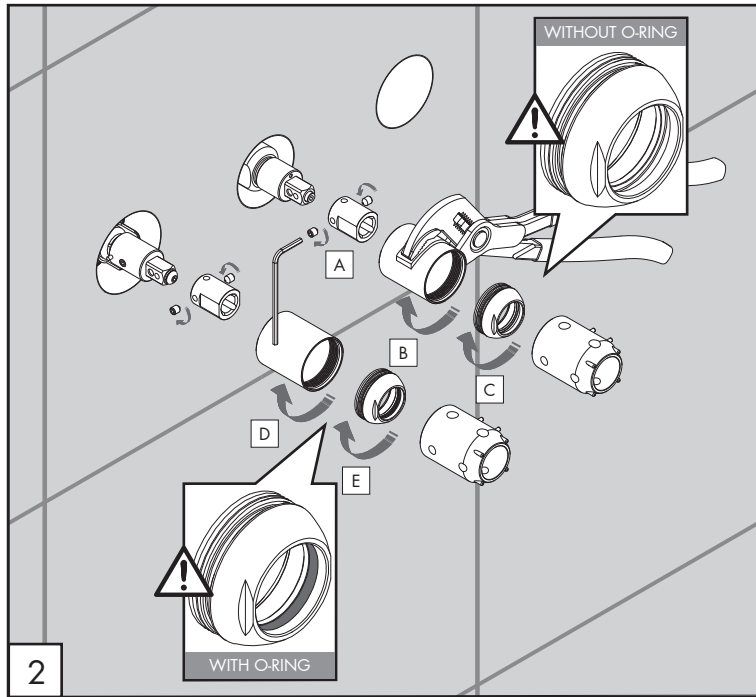
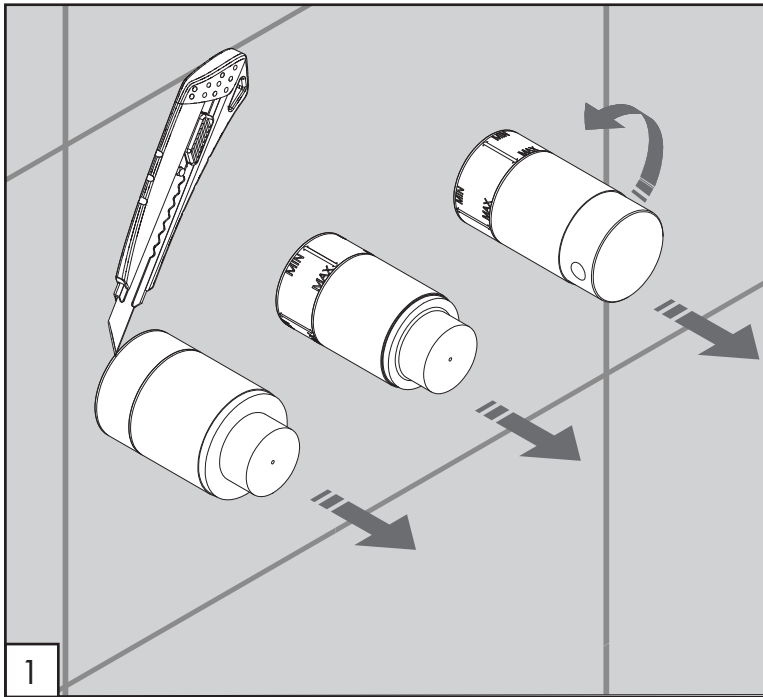

# INV60Y \_ REV11



## AVVERTENZE TECNICHE

Risciacquare bene le tubazioni prima del montaggio ed evitare sbalzi di pressione fra i raccordi d'acqua fredda e d'acqua calda. In caso di pressioni statiche superiori a 5 bar si raccomanda l'installazione di un riduttore di pressione per evitare danni alla cartuccia.

## TECHNICAL WARNINGS

The pipes have to be rinsed thoroughly before installation. Avoid pressure differences between hot and cold water supply. Use of a pressure reducer when static pressure is higher than 5 bar to avoid damage of the cartridge.

## TECHNISCHE WARNUNG

Spülen Sie die Leitungen vor dem Einbau und verhindern Sie Wasserdruckwechsel zwischen kalt und warm Wasserverbindungen. Wenn Wasserdruck größer als 5 bar ist, bitte reduzieren Sie den Systemdruck, um Beschädigung der Kartusche zu verhindern.

## ADVERTENCIA TÉCNICA

Los tubos tienen que ser enjuagados a fondo antes de la instalación. Evitar grandes diferencias de presión entre las conexiones de agua caliente y fría. En caso de presión estática mayor de 5 bar, se recomienda el uso de un adaptador de presión para evitar daños en el cartucho.

## ADVERTISSEMENTS TECHNIQUES

Rincer les tuyaux avant l'installation. Eviter des grandes différences de pression entre l'eau froide et chaude. En cas de pressions statique de plus de 5 bar, nous vous recommandons d'installer un réducteur de pression pour éviter des dommages à la cartouche.

## PORTATE / FLOW RATE

BAR	uscita 1 / outlet 1		uscita 3 / outlet 3	
	l/min	gpm	l/min	gpm
1	11,2	2.9	11,7	3.1
2	15,8	4.2	16,6	4.4
3*	19,2	5.1	20,2	5.3
4	22,0	5.8	23,3	6.2
5	24,9	6.6	26,1	6.9

BAR	uscita 2 doccia / hand shower outlet 2			
	acciaio inox / stainless steel		gomma siliconica / silicone rubber	
	l/min	gpm	l/min	gpm
1	8,7	2.3	5,3	1.4
2	12,6	3.3	7,7	2.0
3*	15,5	4.1	9,6	2.5
4	18,1	4.8	11,0	2.9
5	20,3	5.4	12,3	3.3

\* Pressione consigliata  
Recommended pressure

max. 65 °C  
max. 149 °F

CEA

ceadesign.it

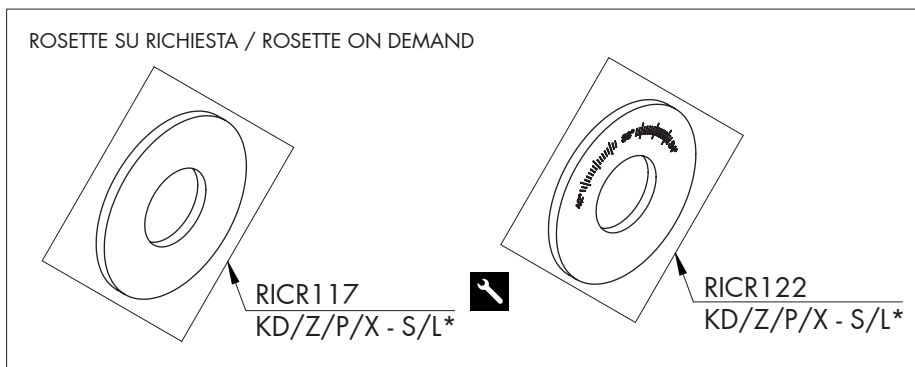
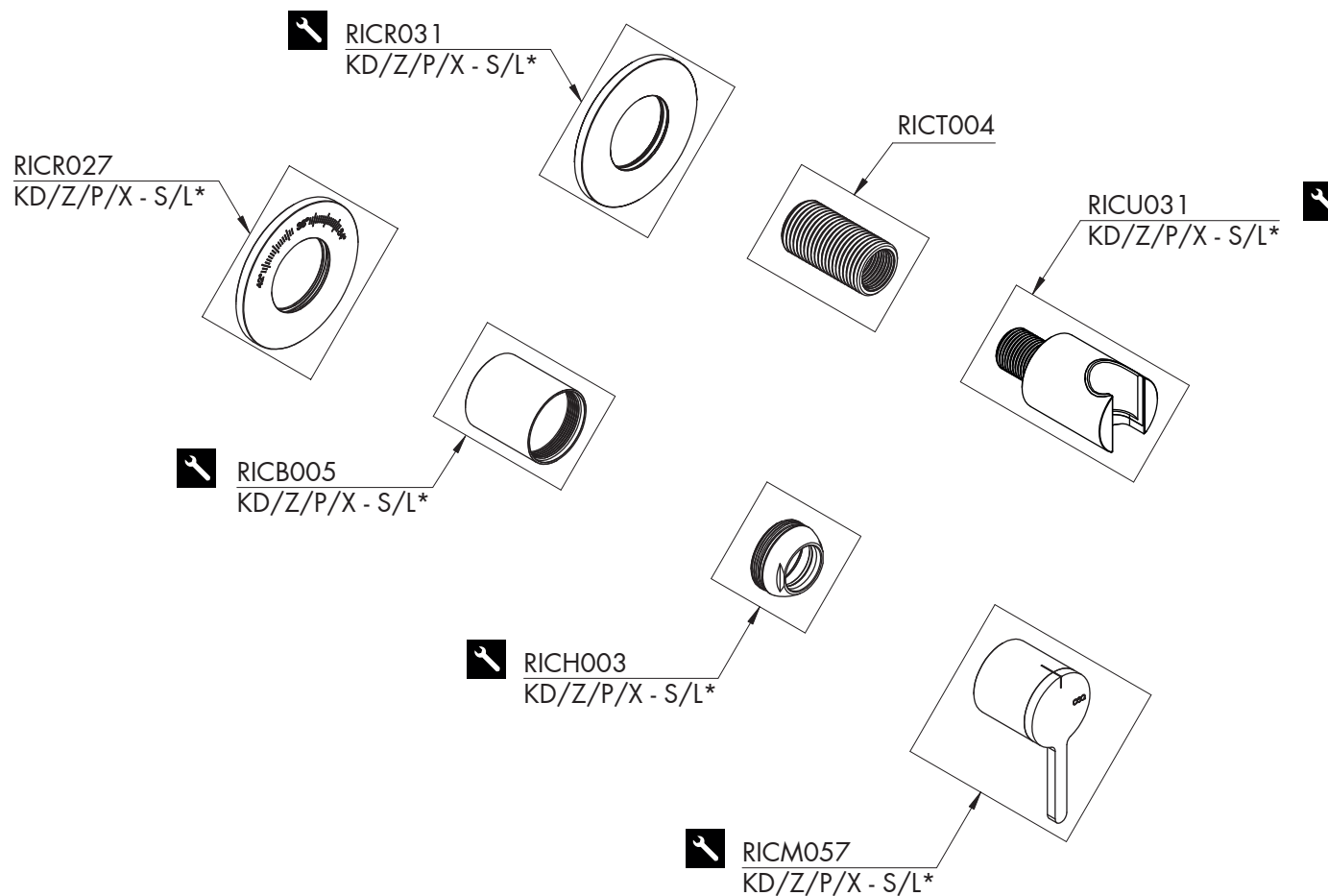

## RICAMBI / SPARE PARTS

RICB005	Carter / Carter
RICH003	Ghiera / Sleeve
RICM057	Maniglia / Handle
RICR027	Rosetta / Rosette
RICR031	Rosetta / Rosette
RICT004	Raccordo / Fitting
RICU031	Supporto doccetta / Hand shower holder

## ROSETTE SU RICHIESTA / ROSETTE ON DEMAND

RICR117	Rosetta Ø esterno 70 mm Rosette external Ø 70 mm
RICR122	Rosetta Ø esterno 70 mm Rosette external Ø 70 mm

## LEGENDA / LEGEND

### ICONE / ICONS

Utensile incluso nel ricambio  
Tool included in spare part

### FINITURE / FINISHES

\*S finitura satinata / satin finish  
L finitura lucidata / polished finish

### FINITURE SPECIALI / SPECIAL FINISHES

KD black diamond  
Z bronzo / bronze  
P rame / copper  
X light gold

## RICAMBI / SPARE PARTS

RICB005	Carter / <i>Carter</i>
RICH035	Ghiera / <i>Sleeve</i>
RICM075	Maniglia / <i>Handle</i>
RICR107	Rosetta / <i>Rosette</i>

## ROSETTA SU RICHIESTA / ROSETTE ON DEMAND

RICR129	Rosetta Ø esterno 70 mm <i>Rosette external Ø 70 mm</i>
---------	--

 Conservare gli strumenti inclusi nel prodotto e utilizzati per l'installazione perché riutilizzabili per i ricambi.

Please, keep the tools included in the item pack and employed for its installation, to re-used them for the spare parts.

Die im Produkt enthaltenen Werkzeuge aufbewahren, da sie für die Ersatzteile wiederverwendet werden können.

No tirar las herramientas incluidas en el producto y usadas durante la instalación puesto que se pueden reutilizar para los recambios.

Veuillez conserver les outils inclus dans la boîte du produit et employés pour son installation, parce que réutilisables pour les pièces de rechange.

## LEGENDA / LEGEND

### ICONE / ICONS

 Utensile incluso nel ricambio  
*Tool included in spare part*

### FINITURE / FINISHES

\*S finitura satinata / *satin finish*  
L finitura lucidata / *polished finish*

### FINITURE SPECIALI / SPECIAL FINISHES

KD black diamond  
Z bronzo / *bronze*  
P rame / *copper*  
X light gold

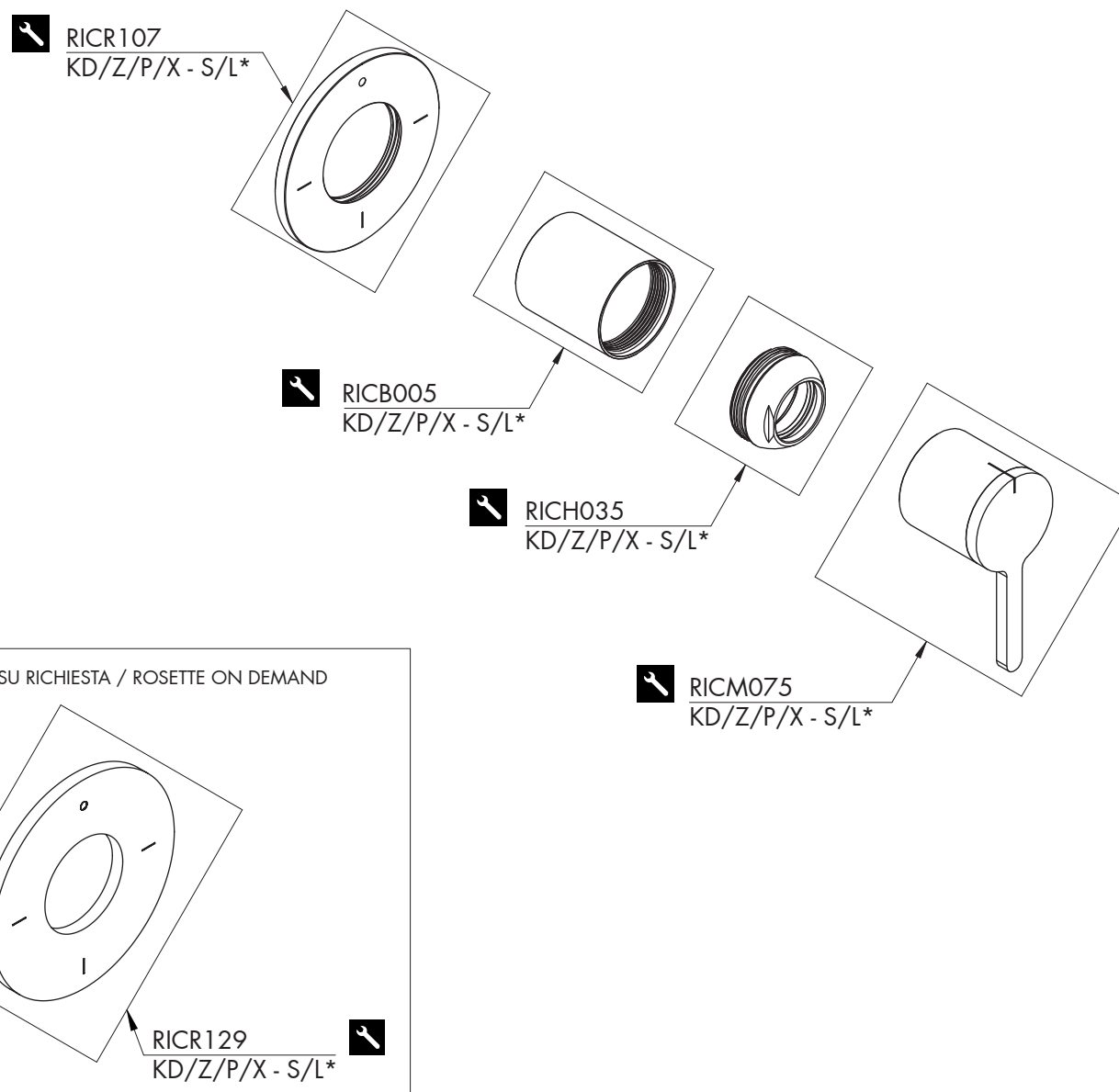

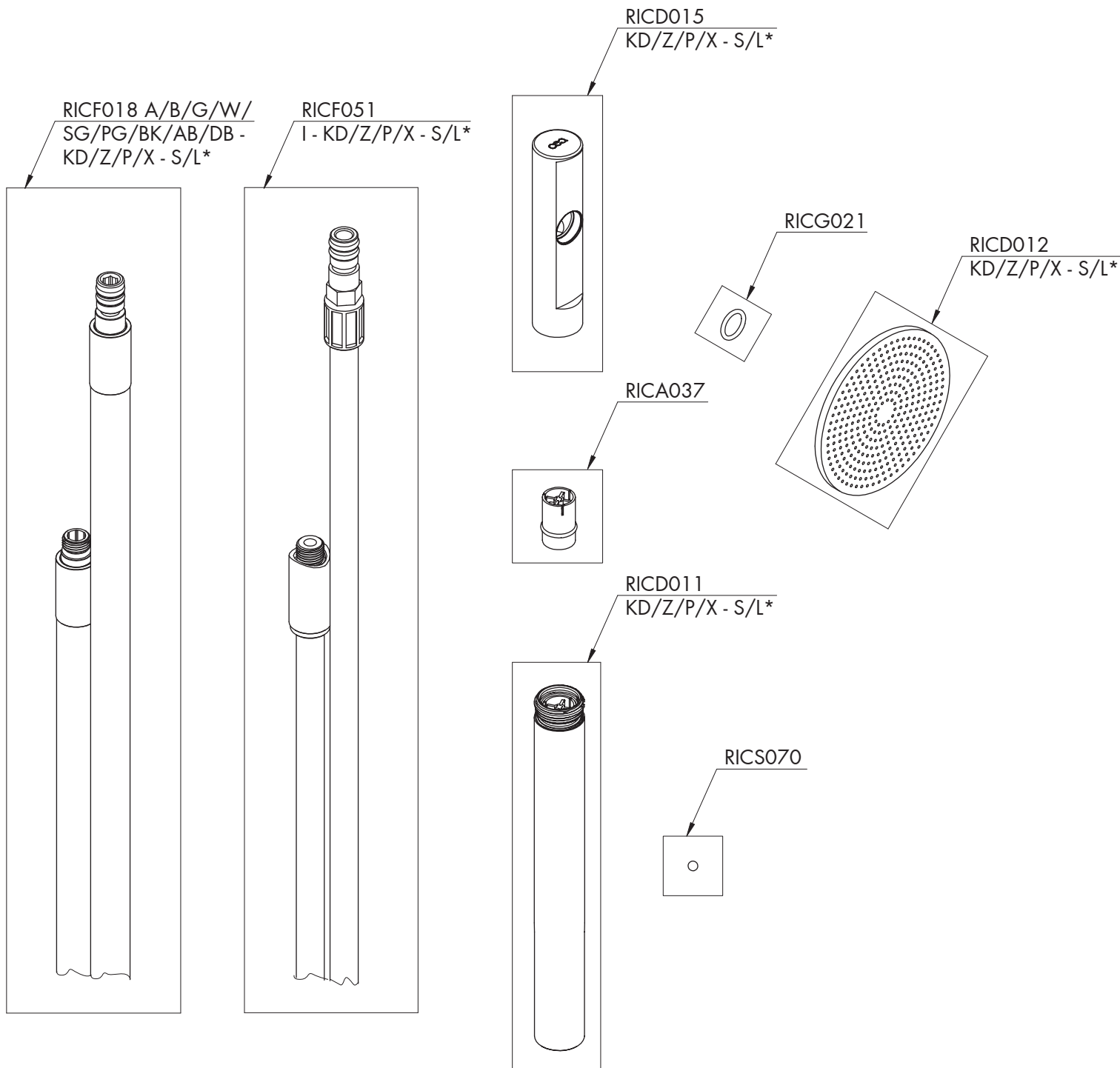

# INV60Y

\_ REV11



## RICAMBI / SPARE PARTS

RICA037	Valvola di non ritorno / <i>Check valve</i>
RICD011	Doccetta / <i>Hand shower</i>
RICD012	Doccetta / <i>Hand shower</i>
RICD015	Doccetta / <i>Hand shower</i>
RICF018	Flessibile / <i>Hose</i>
RICF051	Flessibile / <i>Hose</i>
RICG021	Guarnizione / <i>Gasket</i>
RICS070	Sfera in acciaio inox Ø 3,5 mm <i>Stainless steel ball Ø 3,5 mm</i>

## LEGENDA / LEGEND

### ICONE / ICONS

 Utensile incluso nel ricambio  
*Tool included in spare part*

### FINITURE / FINISHES

\*S finitura satinata / *satin finish*  
L finitura lucidata / *polished finish*

### FINITURE SPECIALI / SPECIAL FINISHES

KD black diamond  
Z bronzo / *bronze*  
P rame / *copper*  
X light gold

### COLORI FLESSIBILE / HOSE COLOURS

A	verde acqua / <i>aqua green</i>	RAL 6027
B	blu cobalto / <i>cobalt blue</i>	RAL 5013
G	grigio antracite / <i>anthracite grey</i>	RAL 7043
W	bianco / <i>white</i>	RAL 9016
SG	grigio seta / <i>silk grey</i>	RAL 7044
PG	verde petrolio / <i>petroleum green</i>	RAL 5020
BK	nero / <i>black</i>	RAL 9004
AB	blu avio / <i>air force blue</i>	RAL 5014
DB	grigio quarzo / <i>quartz grey</i>	RAL 7006
I	acciaio inox / <i>stainless steel</i>	

# CEA