

INV122

_REV14



DESIGN
NATALINO MALASORTI



INV122/INNOVO
AISI 316L STAINLESS STEEL

Gruppo doccia con miscelatore
termostatico e 2 rubinetti d'arresto

*Thermostatic shower mixer set
with 2 shut-off valves*



Alta portata (≥ 25 l/min)
High water flow (≥ 25 l/min / ≥ 6.6 gpm)



Possibilità di installazione a 90°
Installation possibility at 90°



Prodotto che necessita di parte incasso
Product that needs built-in part



Staffa ausiliaria per cartongesso / fibrogesso
Auxiliary bracket for plasterboard / fiber-board structures

MANUTENZIONE / MAINTENANCE

NON UTILIZZARE
DO NOT USE



acido clorico e muriatico
chloric and muriatic acid



acido fluoridrico
hydrofluoric acid



ipoclorito di sodio
chlorine bleach

UTILIZZARE
TO USE



detergente a pH neutro
neutral pH detergent

Questi disegni sono proprietà di CEADDESIGN SRL s.u. pertanto non potranno essere utilizzati e/o comunicati a terzi, anche in forma parziale, senza preventiva autorizzazione. CEADDESIGN SRL s.u. si riserva il diritto di apportare modifiche ai disegni al fine di migliorare il prodotto.

CEADDESIGN SRL s.u. has the property rights on these drawings, therefore they cannot be used and/or transferred to third party, even in partial form, without any prior authorization. Furthermore CEADDESIGN SRL s.u. reserves the right to apply any change to these drawings in order to upgrade the product.

CEA

ceadesign.it

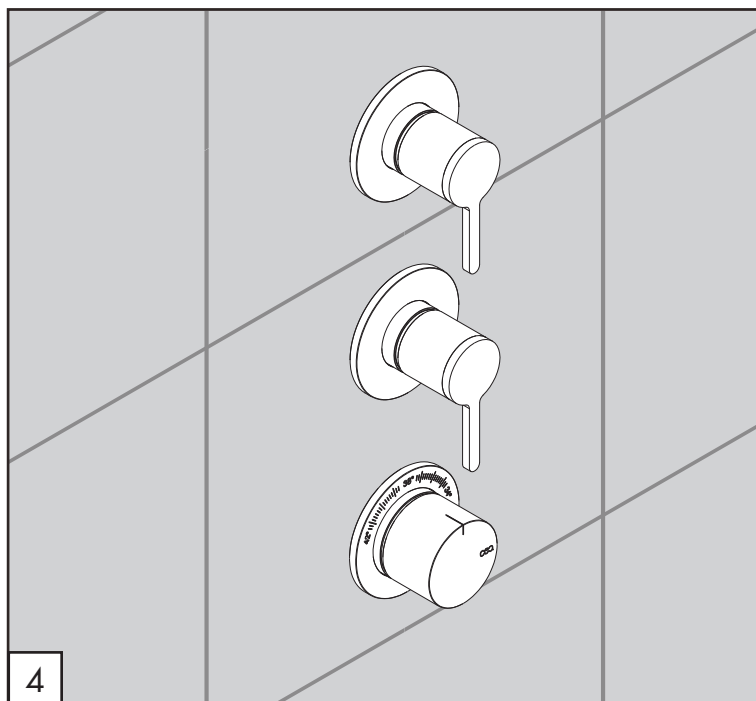
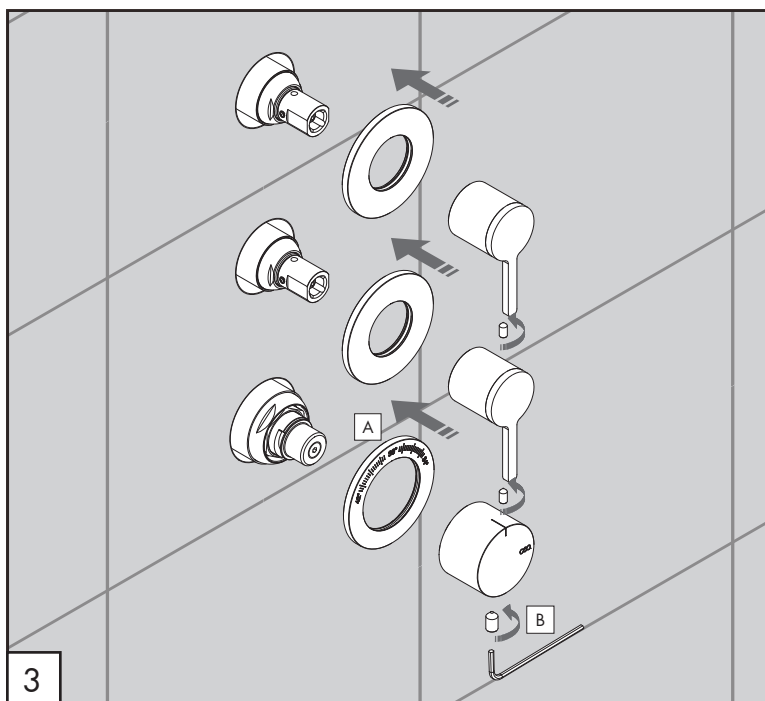
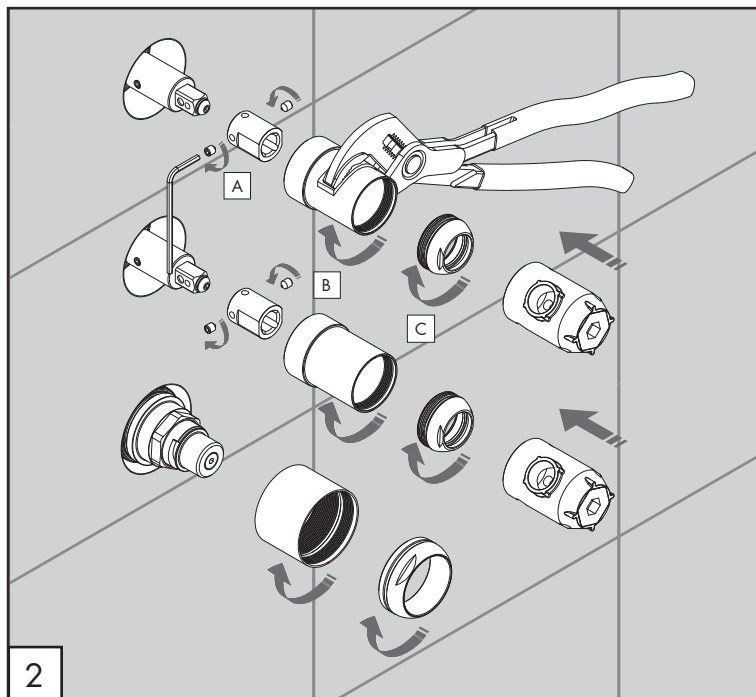
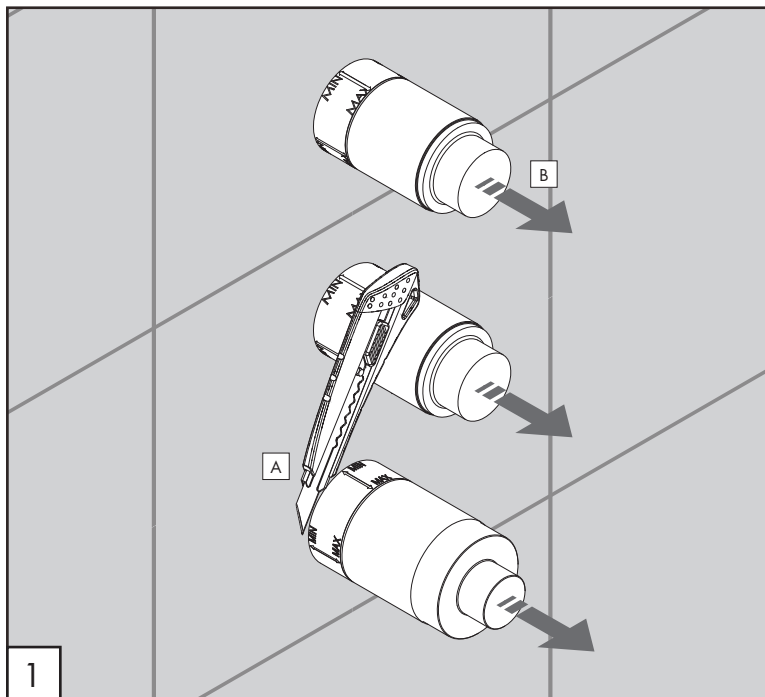

INV122

_REV14



AVVERTENZE TECNICHE

Risciacquare bene le tubazioni prima del montaggio ed evitare sbalzi di pressione fra i raccordi d'acqua fredda e d'acqua calda. In caso di pressioni statiche superiori a 5 bar si raccomanda l'installazione di un riduttore di pressione per evitare danni alla cartuccia.

TECHNICAL WARNINGS

The pipes have to be rinsed thoroughly before installation. Avoid pressure differences between hot and cold water supply. Use of a pressure reducer when static pressure is higher than 5 bar to avoid damage of the cartridge.

TECHNISCHE WARNUNG

Spülen Sie die Leitungen vor dem Einbau und verhindern Sie Wasserdruckwechsel zwischen kalt und warm Wasserverbindungen. Wenn Wasserdruck größer als 5 bar ist, bitte reduzieren Sie den Systemdruck, um Beschädigung der Kartusche zu verhindern.

ADVERTENCIA TÉCNICA

Los tubos tienen que ser enjuagados a fondo antes de la instalación. Evitar grandes diferencias de presión entre las conexiones de agua caliente y fría. En caso de presión estática mayor de 5 bar, se recomienda el uso de un adaptador de presión para evitar daños en el cartucho.

ADVERTISSEMENTS TECHNIQUES

Rincer les tuyaux avant l'installation. Eviter des grandes différences de pression entre l'eau froide et chaude. En cas de pressions statique de plus de 5 bar, nous vous recommandons d'installer un réducteur de pression pour éviter des dommages à la cartouche.

PORTATE / FLOW RATE

BAR	l/min	gpm
1	18,9	5.0
2	27,4	7.2
3*	33,4	8.8
4	38,0	10.0
5	42,0	11.1

* Pressione consigliata
Recommended pressure

🌡️ max. 65 °C
🌡️ max. 149 °F

CEA

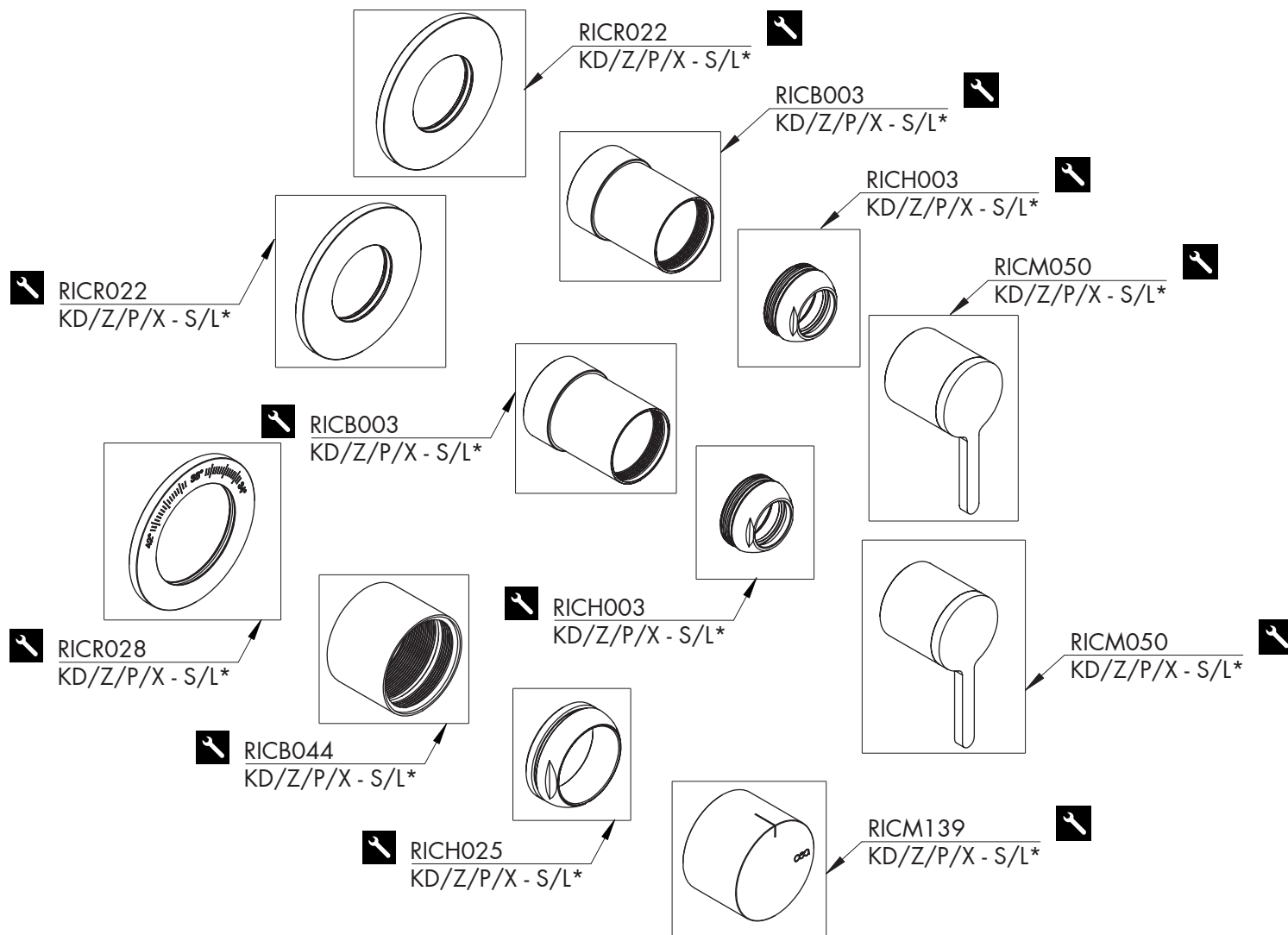

RICAMBI / SPARE PARTS

RICB003	Carter / Carter
RICB044	Carter / Carter
RICH003	Ghiera / Sleeve
RICH025	Ghiera / Sleeve
RICM050	Maniglia / Handle
RICM139	Maniglia / Handle
RICR022	Rosetta / Rosette
RICR028	Rosetta / Rosette

ROSETTE SU RICHIESTA / ROSETTE ON DEMAND

RICR123	Rosetta Ø esterno 70 mm Rosette external Ø 70 mm
RICR117	Rosetta Ø esterno 70 mm Rosette external Ø 70 mm

⚠ Conservare gli strumenti inclusi nel prodotto e utilizzati per l'installazione perchè riutilizzabili per i ricambi.

Please, keep the tools included in the item pack and employed for its installation, to re-used them for the spare parts.

Die im Produkt enthaltenen Werkzeuge aufbewahren, da sie für die Ersatzteile wiederverwendet werden können.

No tirar las herramientas incluidas en el producto y usadas durante la instalación puesto que se pueden reutilizar para los recambios.

Veuillez conserver les outils inclus dans la boîte du produit et employés pour son installation, parce que réutilisables pour les pièces de rechange.

LEGENDA / LEGEND

ICONE / ICONS

🔧 Utensile incluso nel ricambio
Tool included in spare part

FINITURE / FINISHES

*S finitura satinata / satin finish
L finitura lucidata / polished finish

FINITURE SPECIALI / SPECIAL FINISHES

KD black diamond
Z bronzo / bronze
P rame / copper
X light gold

ROSETTE SU RICHIESTA / ROSETTE ON DEMAND

