

INV120_REV15



DESIGN
NATALINO MALASORTI



INV120/INNOVO
AISI 316L STAINLESS STEEL



Gruppo doccia con miscelatore
termostatico e deviatore 2/3 vie

*Thermostatic shower mixer set with
2/3 way diverter*



Alta portata (≥ 25 l/min)
High water flow (≥ 25 l/min / ≥ 6.6 gpm)

Possibilità di installazione a 90°
Installation possibility at 90°

Prodotto che necessita di parte incasso
Product that needs built-in part

FIX Staffa ausiliaria per cartongesso / fibrogesso
Auxiliary bracket for plasterboard / fiber-board structures

MANUTENZIONE / MAINTENANCE

NON UTILIZZARE DO NOT USE		acido clorico e muriatico <i>chloric and muriatic acid</i>
		acido fluoridrico <i>hydrofluoric acid</i>
		ipoclorito di sodio <i>chlorine bleach</i>
UTILIZZARE TO USE		detergente a pH neutro <i>neutral pH detergent</i>

Questi disegni sono proprietà di CEADDESIGN SRL s.u. pertanto non potranno essere utilizzati e/o comunicati a terzi, anche in forma parziale, senza preventiva autorizzazione. CEADDESIGN SRL s.u. si riserva il diritto di apportare modifiche ai disegni al fine di migliorare il prodotto.

CEADDESIGN SRL s.u. has the property rights on these drawings, therefore they cannot be used and/or transferred to third party, even in partial form, without any prior authorization. Furthermore CEADDESIGN SRL s.u. reserves the right to apply any change to these drawings in order to upgrade the product.

ceadesign.it

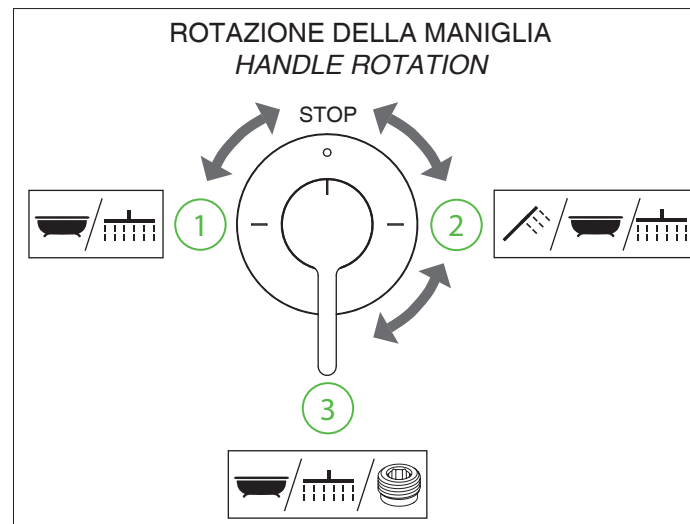
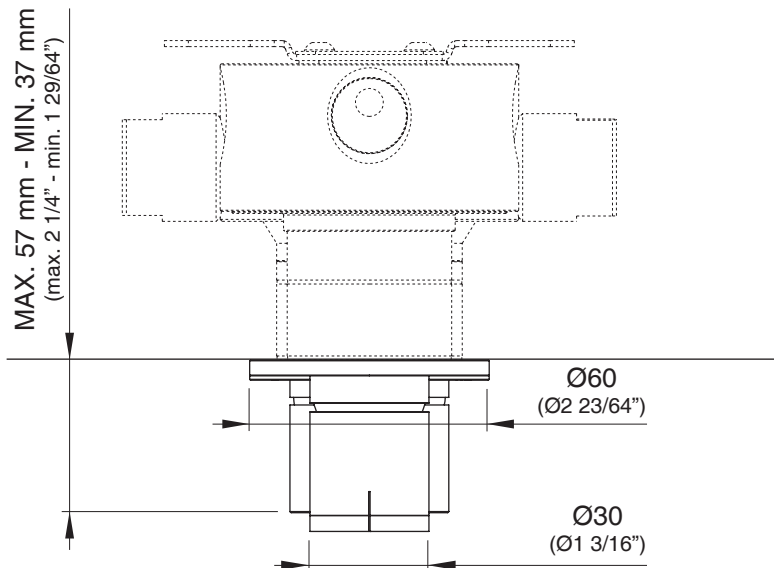
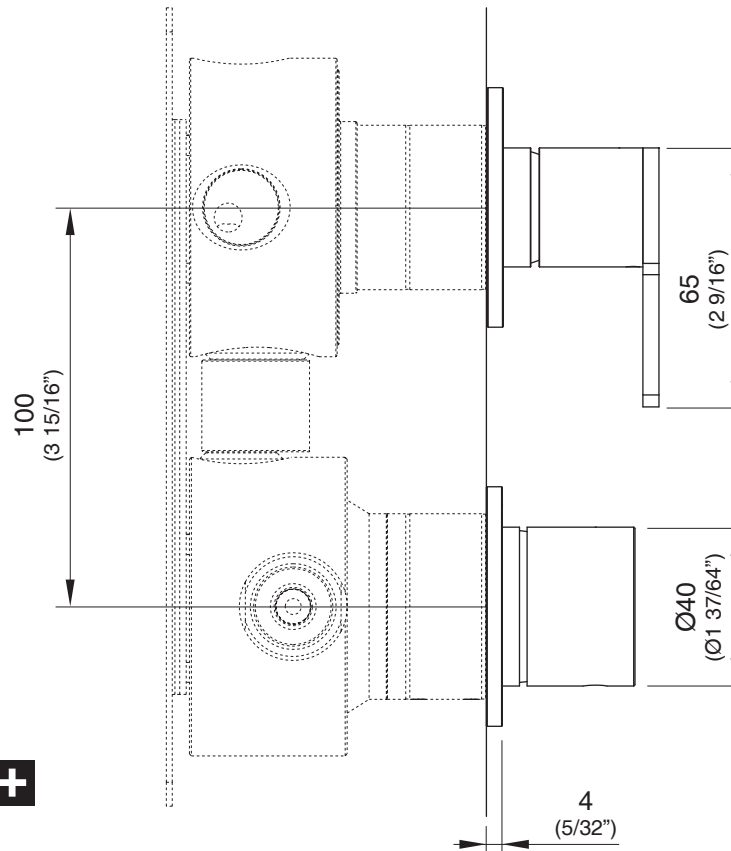
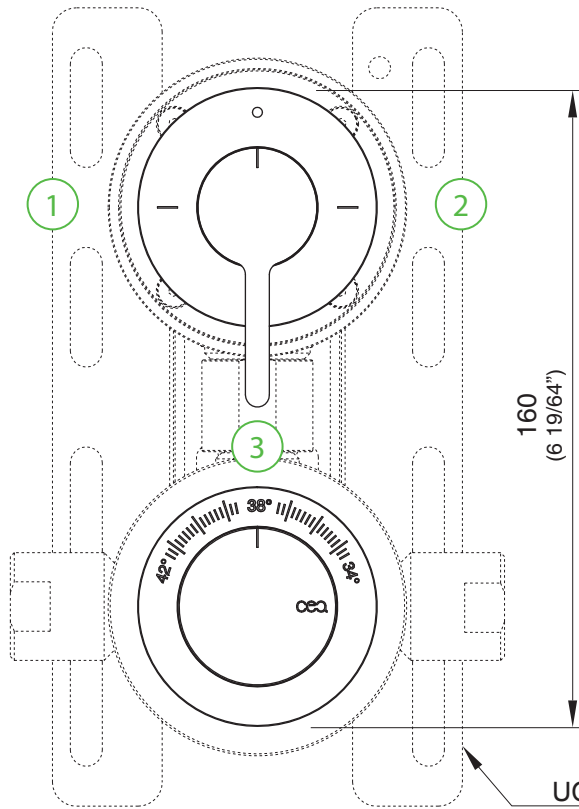

UCS27

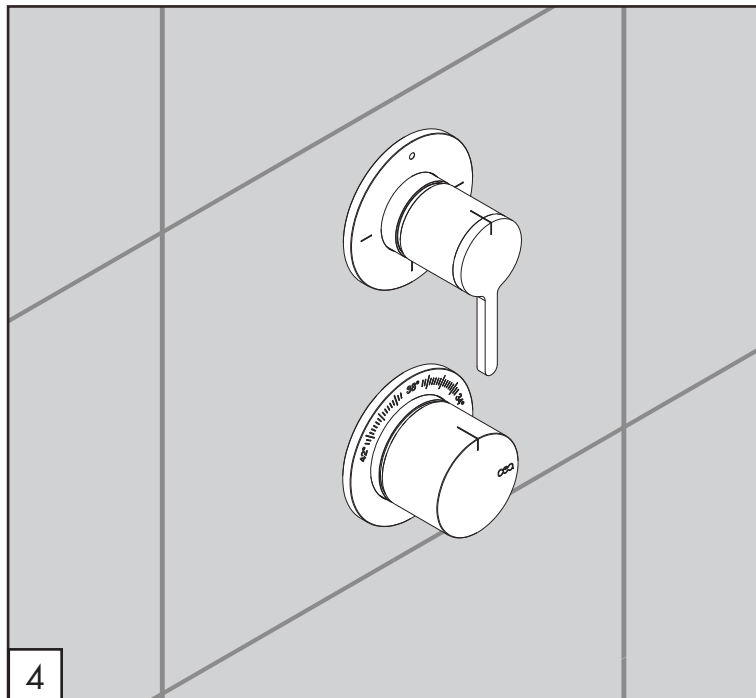
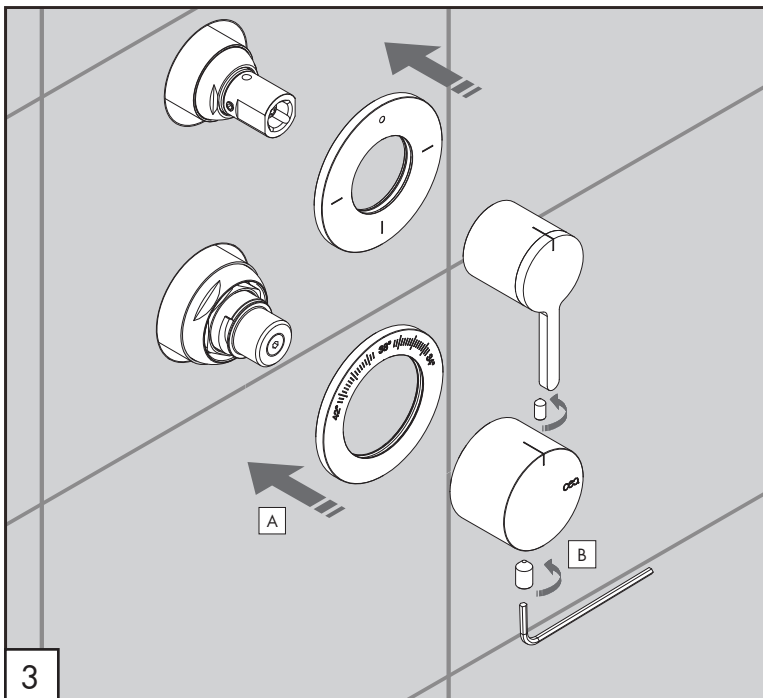
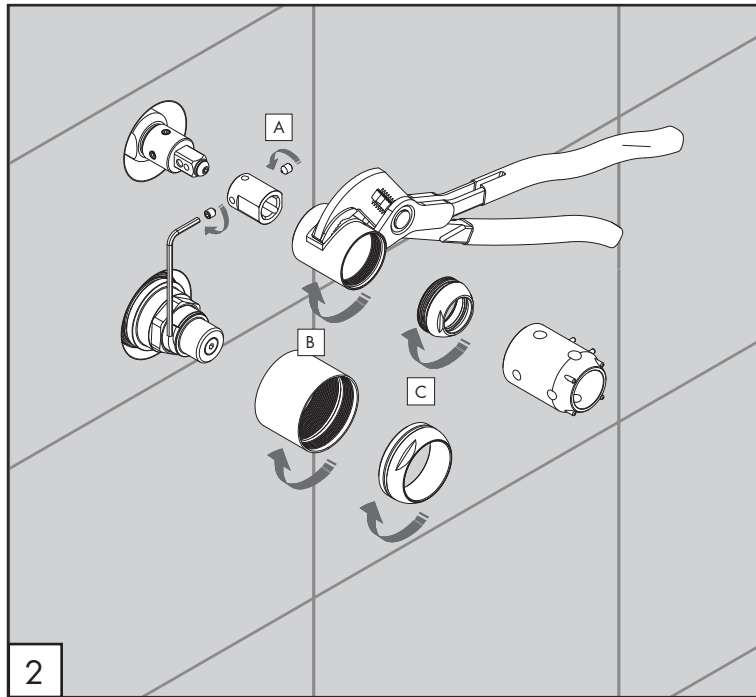
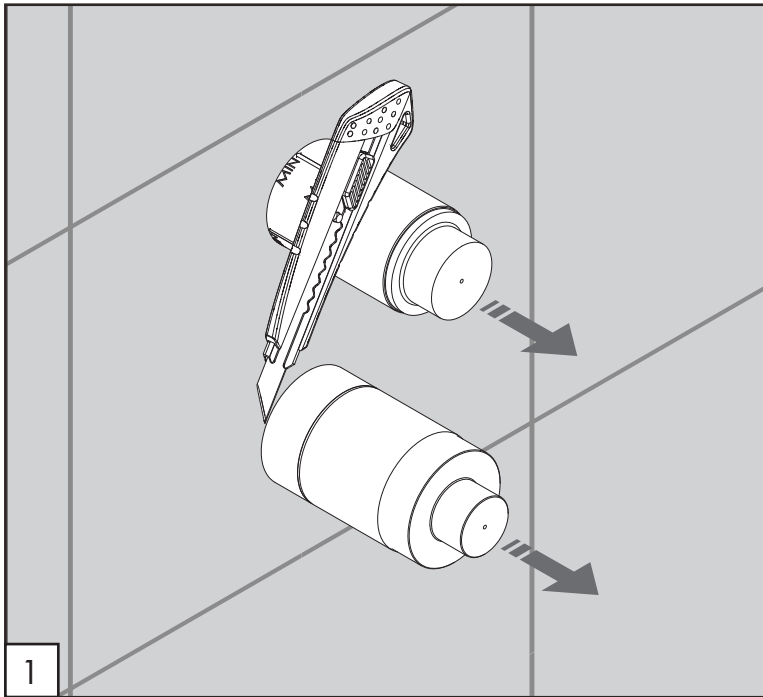

AVVERTENZE TECNICHE

Risciacquare bene le tubazioni prima del montaggio ed evitare sbalzi di pressione fra i raccordi d'acqua fredda e d'acqua calda. In caso di pressioni statiche superiori a 5 bar si raccomanda l'installazione di un riduttore di pressione per evitare danni alla cartuccia.

TECHNICAL WARNINGS

The pipes have to be rinsed thoroughly before installation. Avoid pressure differences between hot and cold water supply. Use of a pressure reducer when static pressure is higher than 5 bar to avoid damage of the cartridge.

TECHNISCHE WARNUNG

Spülen Sie die Leitungen vor dem Einbau und verhindern Sie Wasserdruckwechsel zwischen kalt und warm Wasserverbindungen. Wenn Wasserdruck größer als 5 bar ist, bitte reduzieren Sie den Systemdruck, um Beschädigung der Kartusche zu verhindern.

ADVERTENCIA TÉCNICA

Los tubos tienen que ser enjuagados a fondo antes de la instalación. Evitar grandes diferencias de presión entre las conexiones de agua caliente y fría. En caso de presión estática mayor de 5 bar, se recomienda el uso de un adaptador de presión para evitar daños en el cartucho.

ADVERTISSEMENTS TECHNIQUES

Rincer les tuyaux avant l'installation. Eviter des grandes différences de pression entre l'eau froide et chaude.

En cas de pressions statique de plus de 5 bar, nous vous recommandons d'installer un réducteur de pression pour éviter des dommages à la cartouche.

PORTATE / FLOW RATE

BAR	uscita 1 / outlet 1		uscita 2 / outlet 2	
	l/min	gpm	l/min	gpm
1	17,3	4.6	11,6	3.1
2	20,4	5.4	16,6	4.4
3*	25,3	6.7	20,3	5.4
4	29,2	7.7	23,1	6.1
5	32,7	8.6	25,7	6.8

BAR	uscita 3 / outlet 3	
	l/min	gpm
1	15,1	4.0
2	21,8	5.8
3*	27,0	7.1
4	31,3	8.3
5	34,9	9.2

* Pressione consigliata
Recommended pressure

max. 60 °C
max. 140 °F

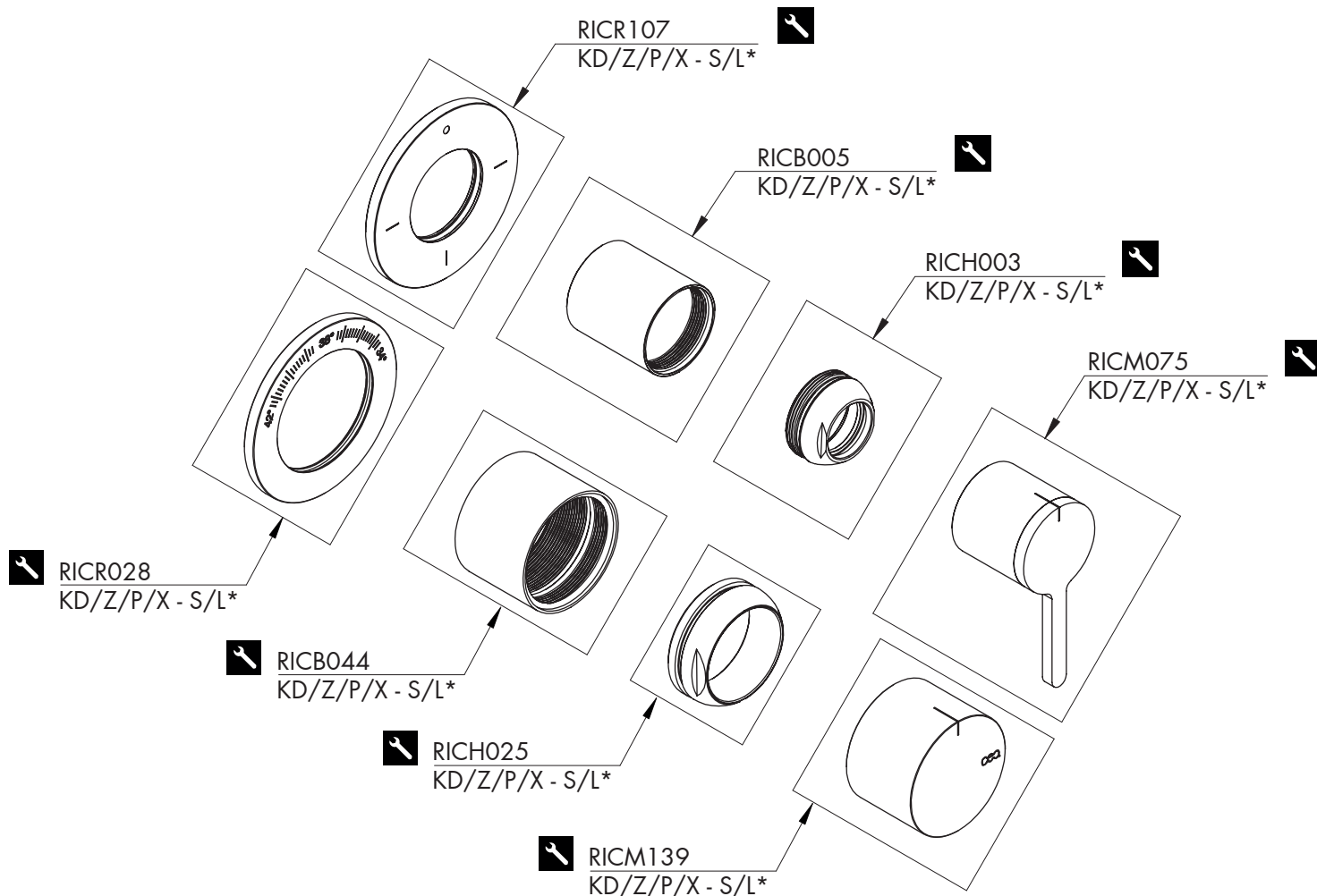

RICAMBI / SPARE PARTS

RICB005	Carter / Carter
RICB044	Carter / Carter
RICH003	Ghiera / Sleeve
RICH025	Ghiera / Sleeve
RICM075	Maniglia / Handle
RICM139	Maniglia / Handle
RICR028	Rosetta / Rosette
RICR107	Rosetta / Rosette

ROSETTA SU RICHIESTA / ROSETTE ON DEMAND

RICR123	Rosetta Ø esterno 70 mm Rosette external Ø 70 mm
RICR129	Rosetta Ø esterno 70 mm Rosette external Ø 70 mm



Conservare gli strumenti inclusi nel prodotto e utilizzati per l'installazione perchè riutilizzabili per i ricambi.

Please, keep the tools included in the item pack and employed for its installation, to re-used them for the spare parts.

Die im Produkt enthaltenen Werkzeuge aufbewahren, da sie für die Ersatzteile wiederverwendet werden können.

No tirar las herramientas incluidas en el producto y usadas durante la instalación puesto que se pueden reutilizar para los recambios.

Veuillez conserver les outils inclus dans la boîte du produit et employés pour son installation, parce que réutilisables pour les pièces de rechange.

LEGENDA / LEGEND

ICONE / ICONS



Utensile incluso nel ricambio
Tool included in spare part

FINITURE / FINISHES

*S finitura satinata / satin finish
L finitura lucidata / polished finish

FINITURE SPECIALI / SPECIAL FINISHES

KD black diamond
Z bronzo / bronze
P rame / copper
X light gold

